

Galician Maritime Technologies // n°6 // 2021

GMT *by* ACLUNAGA

The Wireless Vessel, the Integrated Service System and the Digital Twin

Detegasa Bets for Digitalization and the Digital Twin

It is Possible to use Smart Technologies in Ship Design

LNG as Alternate Power Source for Maritime Propelling. GABADI SL and the Mark III Technology

The Firefighting Boat AISTER MZ12

Emergence of the Hazardous Materials Agreements

The Interview: Talleres López Vilar S.L.



- Separadores de aguas oleosas
- Incineradores de residuos
- Sistemas de repostaje de helicópteros
- Hidróforos y Calentadores

MÁS DE
3.000
equipos
SUMINISTRADOS

PRESENCIA
a nivel
mundial

Plantas de tratamiento de aguas residuales



Biológicas



Biorreactores de membrana

Emergence of the Hazardous Materials Agreements



www.detegasa.com

+34 981 49 40 00

commercial@detegasa.com

¡Síguenos en LinkedIn



GALICIAN MARITIME TECHNOLOGIES // nº6 // 2021

2 EXPONAV // The Wireless Vessel, the Integrated Service System and the Digital Twin

6 DETEGASA Bets for Digitalization and the Digital Twin

11 SENER // It is Possible to use Smart Technologies in Ship Design

16 LNG as Alternate Power Source for Maritime Propelling GABADI SL and the Mark III Technology

20 VA de BARCOS // The Firefighting Boat AISTER MZ12

22 LLOYD'S REGISTER // Emergence of the Hazardous Materials Agreements

26 The Interview: TALLERES LÓPEZ VILAR S.L.

The year 2020 has undoubtedly marked an important turning point for all of us. The year of the pandemic, of survival, both personal and labour. The year of adaptation for many. A year that, however, and in my case in question, has been good for the Port, that has managed to face the uncertainty and that, thanks to the efforts of all those who make up its Port Community, it has known not only to stand up to the coronavirus, but has also managed to overcome and take stance at the head of the rest of Spanish ports. But not for this reason we should be settle. If this year has taught us something, it has been not to conform and to think not only in the present, but also in the medium-long term. The Port of Vigo needs to grow. And everyone knows it: we need more mooring lines. We need the South exit and the railway connection with the Bouzas Ro-Ro Terminal, which weakens our weight. Either Vigo strengthens its port on that line or traffic will progressively leave, including containers, to other nearby ports.

But, in addition, at the Port of Vigo we have the exciting challenge of consolidating ourselves as one of the main ports on the Atlantic coast, so that we continue to be a national, European and international reference.

Thus, we want to continue strengthening our path focused on continuing to “growing in blue”; a bet by which we understand our active contribution to sustainable development, with the challenge and commitment to the conciliation of the social, economic and environmental dimensions, working on three key axes: economic promotion from innovation and digitalisation; social inclusion, promoting the humanisation of our activity and the generation of employment; and the preservation of our envi-

ronment and energy self-sufficiency.

Since the launch of the Blue Growth strategy, there have been many successes and good results: in 2016 we proposed a total of 38 projects, which have been increased to reach 46 in 2020..

The participation of the Shipbuilding Sector in the Blue Growth Plan is also very relevant. On one side, through the creation and functioning of a specific working group, where we work on joint challenges for a sustainable development of the sector. On the other side, it should not be forgotten that ACLUNAGA is a founding member of the MarinnLeg Foundation, created in 2018. Additionally, its participation in strategic projects with community and national funding in different areas has also been key: MarE-Net, led by the Campus do Mar, which aims to reinforce training in the maritime port area and create a centre of excellence in training; Green Bay Vigo, of an environmental nature and presented to the Next Generation funds, which aims to build electric and hybrid vessels for traffic in the Vigo’s estuary, or Living Port (Peiraos do Solpor), with Cardama participating in the development of an underwater observatory for the public to view the “gardens” of the Port of Vigo. But, in the social sphere, we also agree on promoting initiatives aimed at improving the habitability and efficiency of fishing vessels, using augmented reality to design more ergonomic vessels with better habitability, within a sector as tough as the fishing industry.

Undoubtedly, we have exciting challenges ahead of us that we will assume with the collaboration of the private sector, the technological centres, the University and the Administration, achieving together our ultimate goal: a sustainable port model.



Jesús Vázquez Almuiña
President of the Vigo’s Port Authority

THE WIRELESS VESSEL, THE INTEGRATED SERVICE SYSTEM AND THE DIGITAL TWIN

RAÚL VILLA CARO, PhD // EXPONAV

Naval and Oceanic Engineer // Master
rvilcar@exponav.org



INTRODUCTION:

There are approximately half a million to one million linear metres of cables laid on the decks on a vessel, which represent a significant volume of weight. This problem will increase in the future, with new vessels built according to “Vessel 4.0” specifications, which will require an increase in the number of sensors and actuators to be wired. From this need was born what was initially called the “wireless ship”, from which the “integrated service system” has evolved.

It should be highlighted that with the arrival of the 4.0 era, an exponential increase in the volume of ship data is expected, consequently this data traffic will have to be managed through communication networks of greater capacity than the current ones.

The “wireless ship”, now “integrated services system (ISS)”, has been developed by Navantia in collaboration with the University of A Coruña (UDC) and the University of Vigo (UVigo). This project was born in the Joint Research Unit (UMI), created between Navantia and the UDC, within the smart vessel section, and is complemented by internal R&D&I activities of the partners involved. In the first conceptual phase of the project, between 2015 and 2018, two well-differentiated actions were carried out, associated to the areas with the greatest volume of wiring: electrical distribution, on the one side, and communications and sensors, on the other. Navantia, UVigo and the UDC are currently carrying out the second phase of this UMI, which will be completed in 2021, and continue to work on the development of the different elements of the system, with the challenge of making this project one of the most innovative in the frigates of the future. Carlos Blanco, Director of

“Research” and responsible for the project on behalf of Navantia, indicated in the summer of 2020 at Exponav that the SSI project was really new, with patents under study, so the ins and outs of the project could not be revealed. It should be noted that the project manager for the UDC is Professor Luis Castedo Ribas and for UVigo the professors Fernando Obelleiro and Jesus Doval.

The ISS must have a close relationship with the vessel’s Digital Twin, a system that will make it possible in the future to link the physical environment of the vessel with the virtual one, with the aim of merging them through the application of modern technologies.



Figure 1: Carlos Blanco at the UMI Conference at Exponav in December 2019 (Source: UDC- Navantia Joint Research Unit)

WIRELESS VESSEL CONCEPT - ISS:

Therefore, the term “ wireless ship “ does not refer to a vessel without cables, but rather to a vessel

that seeks to reduce the amount of existing cables by using a common infrastructure that supports and provides integral coverage for multiple services such as lighting, loudspeaker system or connectivity (both for equipment and systems, and for personal devices and body devices, cameras and entertainment systems). The initial objective of the project aimed at a potential reduction of cables by around 20%, and a facilitation in the incorporation of new 4.0 technologies in vessels, the latter being the most interesting novelty.

The “wireless” project included two different actions associated with the areas with the highest volume of cabling. These are as follows:

- Electrical distribution: in this case, action in the field of electrical distribution combines the advantages of high voltage, the use of rigid connection devices, and the use of energy storage systems. In addition to these advantages, there is an optimised geographical distribution of the elements, in order to achieve flexible plant alternatives, with a high survival capacity and with savings in installation weight compared to current vessels.
- The distribution of certain “data” systems: integrating lighting, communications, access services and sensors into a single system (ISS), which forms the vessel’s nervous system.

As a summary, it could be understood that this system pretends to replace a current lighting equipment, by an equipment with intelligent led lighting, which would be provided with the capacity of communication with the equipment and the people, and to which different sensors would be added that would increase, among others, the current capacity of the SICP (integrated platform control system). The way to develop this solution would be through a “net tree”

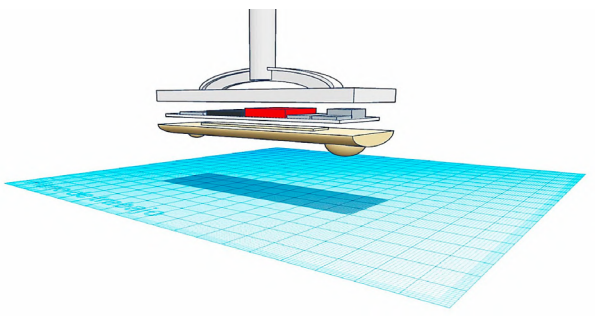

Figure 2: ISS Concept (Source: Joint Research Unit UDC - Navantia)

The system is expected to cover multiple functionalities, including among others:

- Intelligent general LED lighting, and visual warnings.
- Internal communications and telephony.
- General loudspeaker system.
- Infrastructure for location and biometric surveillance of the crew.
- Wireless access from mobile terminals (tablets, PDAs, etc.) to certain services.

ELEMENTS THAT SHAPE THE ISS SYSTEM:

The lamps are intelligent physical units that integrate the different electrical and electronic elements that support the functions and communications with the systems and users of the vessel. There are several types initially known within the workteam as “minions”(Multi-element Intelligent Node Integrating Open Network Solutions) and “grus” (Graphic Remote Units).



Figure 3: Intelligent light prototype (Source: UDC - Navantia Joint Research Unit)

The lights will be the visible elements of the ISS, as they are the link between the users and the vessel’s systems, so they must integrate the different electrical and electronic elements that support the capabilities. This is achieved through different modules integrated within a common casing.

The system will be supplied in a similar way to the current lighting of the systems, either by normal electrical distribution or by emergency, and will have redundancy to ensure the continuation of the service in accordance with the requirements and specifications of the contract established for each of the functionalities provided.

The ISS will be integrated with the Digital Twin, communications system and vessel's SICP, providing all three systems with a large amount of data in a usable time.



Figure 4: Lamp working in a cabin (Source: UDC - Navantia Joint Research Unit)

DIGITAL TWIN AND DIGITAL MODEL:

The "Digital Twin (DT)" is a key concept for digitalisation and in particular for the 4.0 Shipyard, which consists of having a virtual replica, beyond a 3D geometric model, of an existing vessel. As information and data are introduced into the DG, it evolves to reflect how the ship is being modified. As an "avatar" of the real vessel, its DT allows the status and condition of the vessel to be displayed, even when it is thousands of miles away, depending on the availability of digital communication resources. The DG can also provide new inputs on the design, construction, operation and services associated with its "Real Twin".

In the virtual environment of the vessel it will be

possible to analyse the data obtained during its life cycle, as well as to generate simulations on models that will allow the identification of recommendations for operation and maintenance tasks (corrective, preventive and predictive), which will mean a great advantage in the face of the client, in the form of greater efficiency in operation, greater safety and better optimisation of life cycle costs. It should be noted that the DT will be developed in parallel with the actual construction of the vessel.

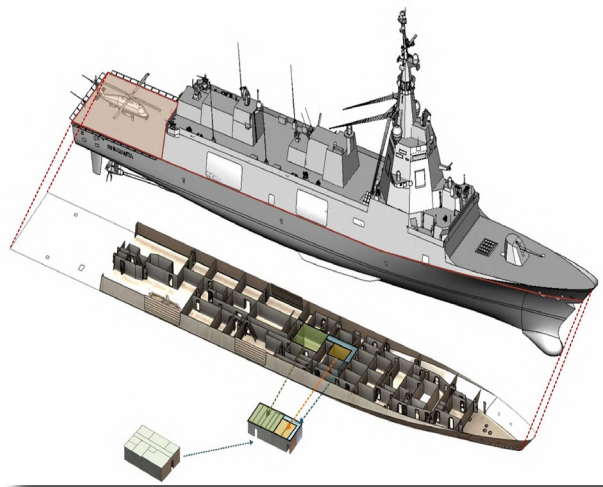

Figure 5: DT Demonstrator (Source: UDC - Navantia Joint Research Unit)

The DT is revolutionizing all industries, bringing value in terms of efficiency, flexibility and functional safety on vessels, since it's much more than a Digital Model (DM). The importance of DT lies in being able to help that decisions are made based on learning the data, and as far as possible, that this help is carried out autonomously.

MD is an information system that contains a 3D graphic representation of the vessel, reflecting its product structure through different levels of hierarchy of its elements. That is to say, the MD only unifies in a structured way, all the logistic data traditionally dispersed in different logistic applications, while the DT appears when we connect the MD to the real ship and the real systems to incorporate, in useful time, both the data related to enlistment and the operation parameters that allow to carry out the processes of predictive maintenance.



Figure 6: Digital Twins (Source: UDC- Navantia Joint Research Unit)



Figure 7: ISS location system (Source: Joint Research Unit UDC- Navantia)

CONCLUSIONS:

The main feature of the “Wireless” project, or rather “Integrated Services System (ISS)”, is to provide a common infrastructure that supports and provides integral coverage to multiple services such as lighting, loudspeakers, and connectivity, both of equipment and systems, as well as of people.

Finally, it should be noted that this system will suppose the introduction of the vessel into the new 4.0 era, allowing interaction between the crew and the ship from any point on the vessel

BIBLIOGRAPHICAL REFERENCES

- Revista General de Marina agosto-septiembre 2018: Apoyo Logístico 4.0.
- IV Jornadas de Difusión de la UMI UDC – Navantia celebradas en la Sala Carlos III de Expo-nav los días 4 y 5 de diciembre de 2019 bajo el título “El Astillero del Futuro”.

DETEGASA BETS FOR DIGITALIZATION AND THE DIGITAL TWIN

ROBERTO CASTELO // DETEGASA ARGOS GROUP



Conceptual Design Managment // commercial@detegasa.com

WHAT IS A DIGITAL TWIN?

One of the most important technological trends in recent years, demanded by the market, is the creation of 'Digital twins'.

Broadly speaking, this technology is nothing more than the generation of a product's a virtual replica, service or process that simulates the behaviour of its physical counterpart, with the aim of monitoring it, analysing its reaction to certain situations, improving its performance and facilitating and optimising its maintenance.

The digital twin leans on the digital mockup of the equipment, which is the digital representation and characterisation of an equipment, composed of 3D models, attributes, and other information. The mockup is the environment where the digital twin comes to life with real-time or synchronous information, offering intelligent assistance services. The digital mockup is a static environment and the twin is a dynamic environment, which allows us to experiment without risk and to know information beforehand, increase efficiency, facilitate maintenance or prevent equipment failures, among other advantages.

The era of connected industry with simulated industry has arrived. The virtual shipbuilding sector worldwide is still to be developed, unlike other sectors. NAVANTIA and the Spanish Navy are convinced of this commitment as a path of no return that will transform processes, products and services, including the way we interact with the machines. Detegasa, as a strategic supplier of both, is determined to bet on this technology and accompany Navantia

and the Spanish Navy on this path of digital transformation, which begins with the F-110 frigates programme, investing in the development of digital twins and digitisation of its main products.

The approach that Detegasa is following for the development of the digital twin of its equipments, consists in place in value all the information and know-how that already existed in the company, integrating them into the team. That is, Detegasa as a manufacturer, has 3D models, attributes of all components, design requirements of the equipment, physical and mathematical models used for the development of the equipment, maintenance needs, most common failures of the equipment... why not value all this information, endowing the equipment with the ability to exploit it?

HOW TO DEVELOP A DIGITAL TWIN?

At the beginning of 2020, Detegasa decided to bet on the digitisation and development of digital twins of its equipments, developing a pilot unit with which to gain the necessary skills and experience in this area.

A technical water supply system was chosen, made up of a pumping system and a hydrophore unit, because even though it is an apparently simple piece of equipment, it allows a multitude of processes to be modelled and analysed: mechanical, electrical, hydraulic, thermodynamic... as well as implementing IoT capabilities and facilitating technologies for the maintenance of the equipment.



Equipments and Pipeline Solutions

Spools

- Robotized piping cut center
- Automatic pipe bending center
- Prefabrication of pipes in carbon steel, stainless steel, cupronickel and alloy steel piping
- Assembly / fitting piping in modules and installations

Heat exchangers, Coils, Evaporators

- Fin tube
- Coils and Batteries of smooth tube
- Coils and Batteries of helical corrugated, semi smooth and smooth finning
- Evaporators of smooth tube and finned tube

Pressure Vessels

- Oil separators
- Inlet Separators
- Economizers
- Ice accumulation tanks
- Freezing tanks with brine
- Liquid and Gas tanks
- Autoclaves and Furnaces
- Multi tubular Heat Exchangers

Spain

Parque Empresarial de Areas - Tuy
Calle Seis s/n - 36711 Tuy (Pontevedra).
T +34 986 342 724

Portugal

Zona Ind. São Pedro da Torre
Lotes 6-7 y 20 - 4930-509 Valença.
T +351 251 838 100

 
PipeWorks PipePt

info@pipeworks.es
www.pipeworks.es

This pilot project has been completed by the end of 2020 and the integration of the equipment in the Navantia Showroom, located in the CIS of Ferrol, is expected at the beginning of this year.

Although all the equipments have their own models, characteristics and peculiarities, the steps followed for the development of this pilot are common for all the equipments and consist of:

1. Identify which parameters are relevant for the operation and maintenance of the equipment: pressures, electrical consumption, flow rates, temperature For all those that are considered critical and serve to know the status of the equipment or to detect faults that are occurring or will occur in the equipment, a sensor must be incorporated that allows us to monitor them.

2. Design the equipment and develop a digital model of it. To do this, the 3D model of the equipment is developed, including all relevant components in the operation and maintenance of the equipment.

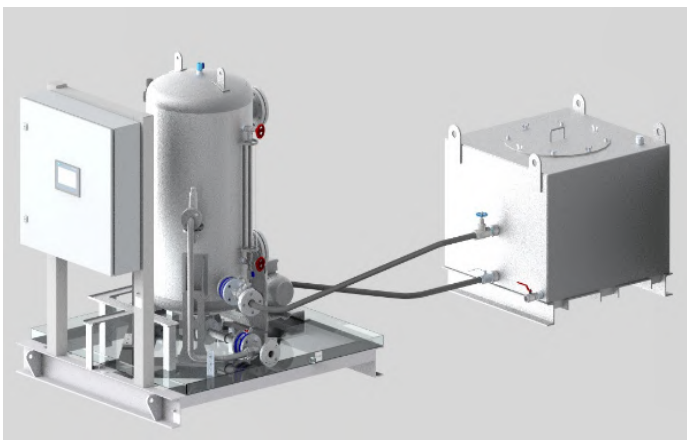

The 3D model must be linked to all equipment information, component data sheets, drawings, schemes, handbooks and other relevant data.

3. Development of the operating and maintenance models of the equipment. This step consists of completing and digitize the mathematical and physical models used to design the equipment, in order to simulate its operation. Simulation makes possible to predict future states of the equipment and also, to implement so-called virtual sensors, which allow us to take virtual measurements that would otherwise be impossible or complex, and also act as redun-

dant sensors to the existing ones of the equipment, comparing the measured values with the simulated ones.

A maintenance model has also been developed, which based on the data from the existing sensors in the equipment and the maintenance and troubleshooting instructions that form part of the equipment manuals, will indicate in a simple way which faults are occurring or are about to occur in the equipment and how they can be solved:

FALLOS ASOCIADO A BOMBA	
Sello mecánico	No hay fallo
Stator	No hay fallo
Impulsor	Posible fallo
Rodamientos	No hay fallo
Cavitacion	No hay fallo

Despite that this step consists, broadly speaking, of taking advantage of the design and maintenance information existing in the company, the programming and integration of the models is perhaps the most novel and therefore the most complex part of this new technology, requiring the use of computer simulation tools. Detegasa has developed this pilot project using Modelica to program the different models:

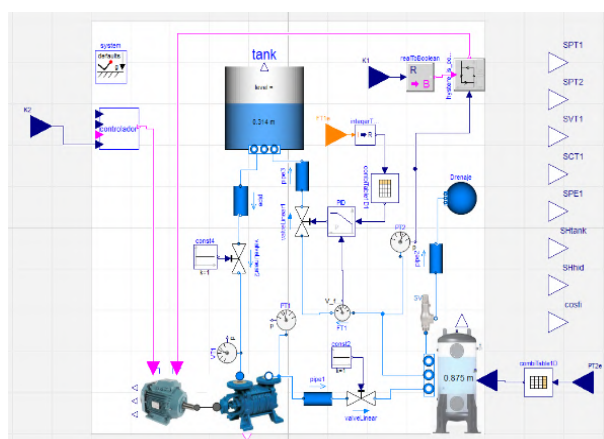

These models, once generated and tested at software level, are exported to an open format (FMU 2.0) that can be executed on third party equipment without needing the software with which

they have been created. In the case of this pilot unit, to execute the models or FMUs, a solution has been chosen based on the incorporation of a ruggedised industrial mini PC (Edge unit), hosted inside the unit's own control panel.

To connect this mini PC with the PLC that physically controls the equipment, the Siemens LiveTwin solution has been used, which allows a simple exchange of information between the PLC and the mini PC. Thus, the PLC constantly sends to the Edge unit the real values of the physical sensors existing in the unit, and this sends back to the PLC all the values calculated by the FMUs (simulated values, virtual sensor values, fault prediction and relevant indications for the operation and maintenance of the unit), which the PLC will show on the display of the unit or send to a remote receiver.

IoT CAPABILITIES

In line with the rise of the internet of things, Degasa has also decided to develop this technology for its equipment. To this end, the pilot unit has been equipped with IoT capabilities, including the possibility of sending data through a local network or through a 3G router included in the unit itself. These IoT capabilities allow the status of the equipment to be consulted remotely from any device with internet access. The data are stored in the unit itself and also in the cloud, in the case of the pilot unit the data are stored every 15 minutes in Azure servers, always guaranteeing their availability, allowing to see in a web environment above an intuitive template of the unit, the real and simulated values, as well as the failures and alarms, both in real time and the stored historical values:

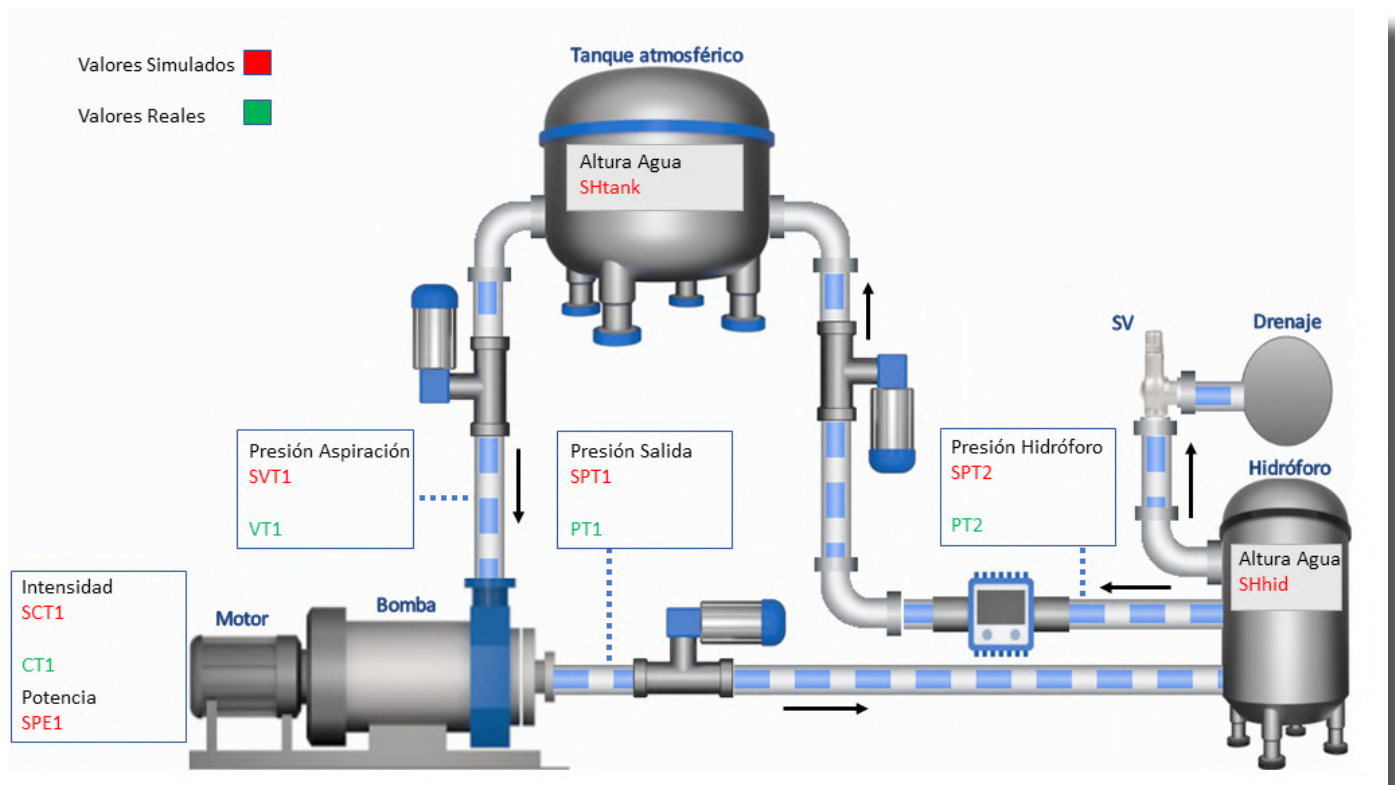

AUGMENTED REALITY ASSISTANT

In parallel to the previous technologies, to complete the digital transformation of Detegasa's equipment, we have developed an augmented reality application that will show us all the maintenance tasks on the equipment itself, broken down into simple tasks animated on the equipment itself. This application can be executed on any recent phone or tablet (iOS or Android) or, preferably, using Microsoft HoloLens 2 glasses. To do this, it's enough to select in the glasses or Tablet, the machine that we want to maintain, focus on it, and the application itself will take care of positioning the virtual model over the real environment, by means of image recognition and markers. The assistant's interface is very simple, allowing us to advance or go back step by step in each operation, using buttons or the gestural interface in the case of glasses.

If the maintenance models allow us to identify or anticipate the most common breakdowns of the equipment, this AR assistant will show us step by step, on the equipment itself, how to solve them.

In addition, the augmented reality assistant includes a detailed guide, step by step, of the equipment's setting to work and the first start up, which in most cases allows the customer or end user to carry out the commissioning by their own means.

The AR application has been developed for the pilot equipment, but its architecture is completely modular and will allow Detegasa to gradually add its entire catalogue of equipment or update the existing ones whenever necessary.

BENEFITS OF DIGITISATION AND THE DIGITAL TWIN

The integration of all the abovementioned technologies provides the following advantages:

- The digital mockup allows easy access to all relevant information.
- The simulation model allows us a double objective: on the one hand, to predict the future state of the equipment, for example, when a tank will be emptied, when the heater will reach the desired temperature, when an equipment will run out of fuel... and on the other hand, to simulate the current state of the equipment, checking if the equipment is

working as planned.

- The maintenance model allows us to identify faults that are occurring or about to occur in the equipment and prescribes the solutions.

- The AR application explains step-by-step how to solve faults or carry out preventive maintenance or commissioning.

- The IoT capability allows us to know the current and historical status of the equipment, from anywhere using any device with internet access.

In this way, the 2 main objectives pursued by Detegasa with digitisation are completed and which represent a great competitive advantage, which are:

- Improve equipment operation, efficiency and availability.

- Greatly facilitate the monitoring and maintenance of equipment.

FUTURE IMPLEMENTATIONS

In addition to the new features already implemented or in the implementation phase, Detegasa is working, in collaboration with Siemens, on the implementation in the short term of the following additional technologies for the pilot equipment:

- Integration of a voice control system, which will allow interaction with the equipment through voice commands. In addition, the application, through the use of a tablet, will allow the visualisation of manuals, plans, quartering and technical data sheets of all the components, among other functionalities.

- Complete simulation of the equipment, including the simulation of the equipment's own PLC (Software in the loop): This feature will allow us to perform virtual tests on the equipment without the need to physically have it available. This characteristic will be very useful to validate future equipment upgrades before physically installing them, reducing the necessary testing time on the equipment itself and minimising problems during the life of the equipment, when it operates under conditions that cannot be physically replicated in the manufacturer's facilities, but can be replicated virtually. It will also greatly facilitate the set up of digital twin implementations in new equipments.

IS IT POSSIBLE TO USE SMART TECHNOLOGIES IN SHIP DESIGN?

ALICIA RAMÍREZ // SENER ENGINEERING
MSc.s in Naval & Oceanic Engineering // alicia.ramirez@sener.es



RODRIGO PÉREZ // SENER ENGINEERING
Naval and Oceanic Engineer // rodrigo.fernandez@sener.es



JOSE A. MUÑOZ // SENER ENGINEERING
Naval and Oceanic Engineer // jesus.muñoz@sener.es



SUMMARY

Smart technologies have arisen on the context of the fourth industrial revolution. Applying these to ship design becomes a matter of analysing carefully, finding the best technologies for each specific process in order to provide value to the end-to-end process.

Even so, there is an underlying difficulty to find areas of application in the Marine Industry, as a result of stationary design and production processes achieved by this industry. In this paper, different approaches for applying disruptive technologies will be evaluated, aiming to highlight the advantages that these provide on different phases of the life cycle of the ship.

1. STATE OF THE ART

Nowadays, smart technologies are widely common topics. The question is do we really understand everything implied in the term? In reality, these are formed by a fusion of multiple technologies that sharing the same ambition: digital transforma-

tion. Nevertheless, the peculiarities and differences found in them require a subtle and delicate analysis in order to establish how they can be applied to each specific industry.

Technologies considered as crucial in this industrial revolution are currently being secured. In particular, the Marine Industry is being forced to enter in this atmosphere of change, following a slow and uncertain adjustment process absolutely needed for their survival. The key at this point is choosing the right strategy and the best way to measure your success on it.

An additional difficulty at this very moment for companies is to keep their strategies intact in spite of the great uncertainty that COVID-19 has brought to our lives. Although methodology may change, strategies must be consistent and straightforward in order to succeed. To evaluate our strategies for the digital transformation, we need to evaluate the correct Key Performance Indicators (KPIs), particular to each process or business. Among the most valuable KPIs, profit making and good practices are key.

According to McKinsey, less than 30% of the companies embarked on this innovative process succeed [1]. Focusing on expectations, there is a 45% chance

to obtain less profit than expected [2]. Therefore, in the sense of digital transformation on a company, how we implant the technologies is as important as the technologies itself.

According to the same report, using agile processes and constituting clear priorities are two of the main factors to really influence a digital transformation. Using Minimum Viable Products (MVP's) with these practices can help companies achieve real success, by providing real results in short time. Selecting the right MVP is decisive to achieve clarity in this fog of digital transformation. As the profits of the marine industry are usually not high, investments and risks are not taken lightly. Therefore, in this new technological hype, a deep understanding of the technologies and how to apply them is indispensable in this

particular sector, in order to avoid mistakes and money waste.

According to Lloyd's Register, QinetiQ and Southampton University, technologies such as Artificial Intelligence (AI), Machine Learning (ML) and Data Analytics (DA) are highlighted for the short term in the Marine Industry [3].

To address the foundations for the implementation of smart technologies in the ship design industry it is necessary to have a minimum comprehension of the underlying basic concepts.

The following image, Figure 1, shows the general understanding of different technologies and the relation among them:

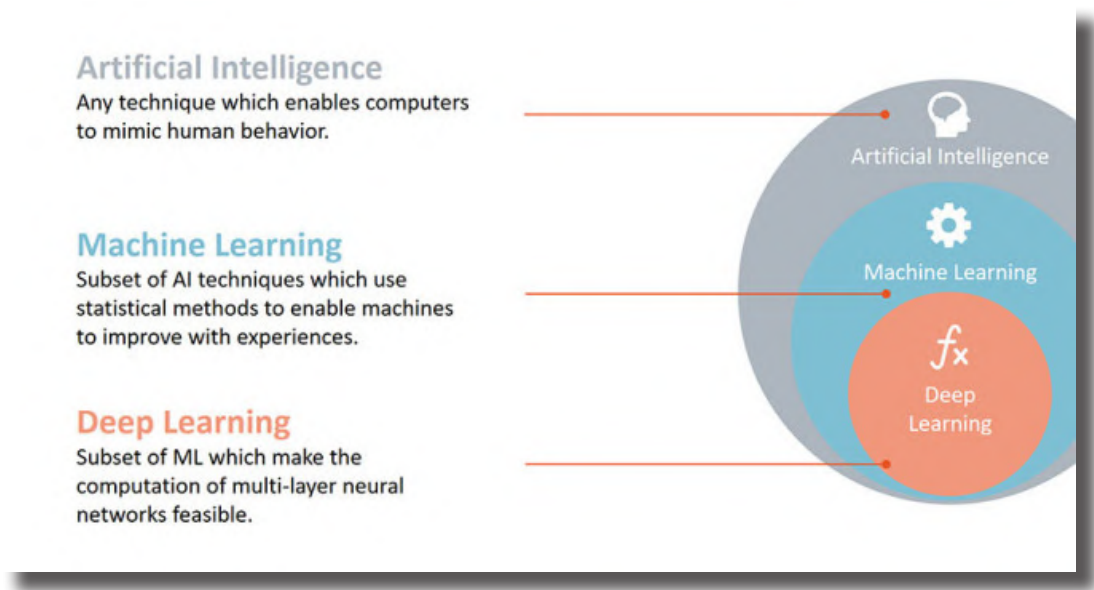

Figure 1: A.I. Techniques [5]

Despite being born as the idea of creating machines capable of simulate human behaviour, AI has evolved to comprise multiple mathematic techniques used in computing and essential to create this “intelligent” machines, sharing a great number of concepts with data science [4].

DA, also called Data Mining, is the discipline dedicated to analysing data to establish relations and provide conclusions. The extraction and preparation of

data are included in this field of study.

ML allows the extraction of patterns from a data set. There are different types of analysis on this field, such as data clustering, support vector machines, association rule learning, Bayes algorithms, and all other algorithms included in Deep Learning (DL).

Figure 2 explains in detail the different components of Machine learning:

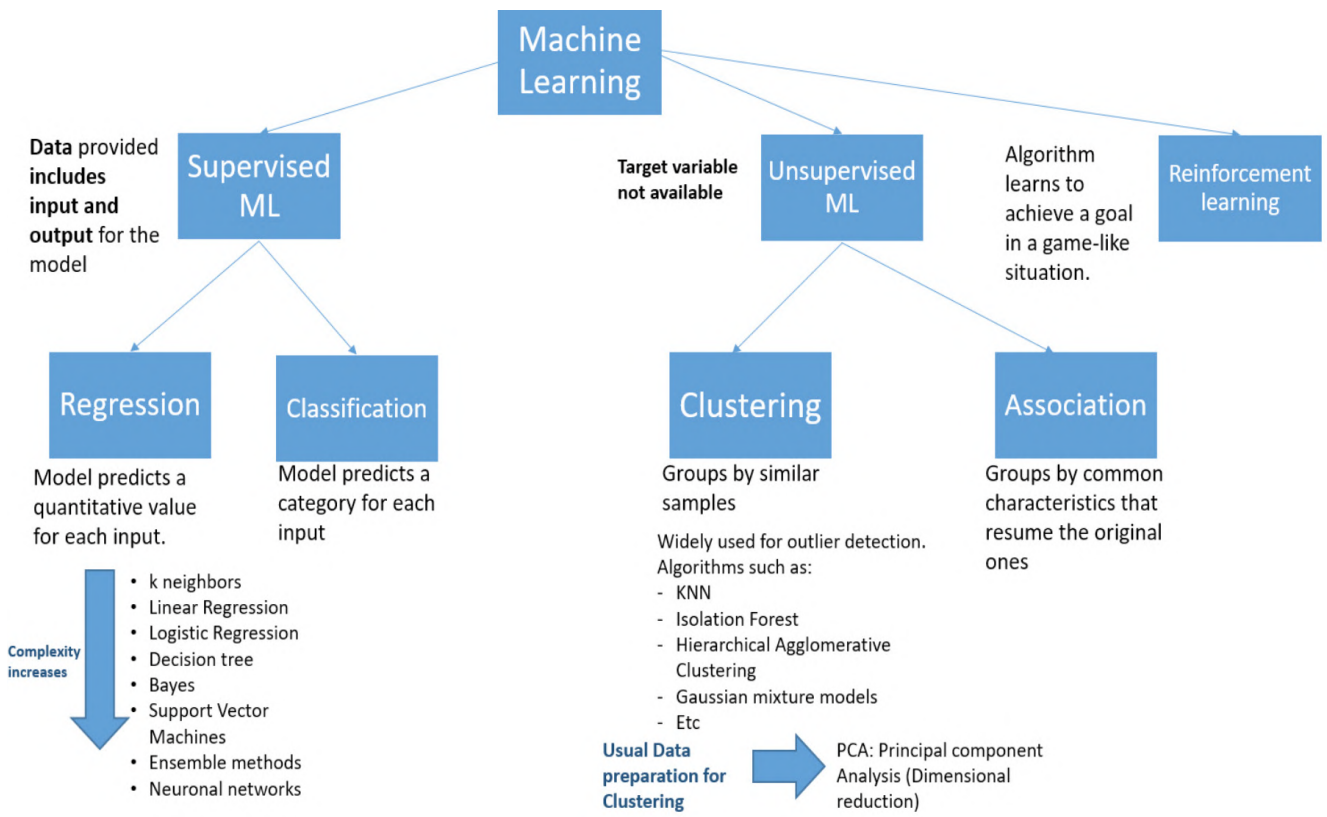

Figure 2: Machine Learning Components [6]

In simple words, ML is the evolution of ruled based systems, being able to distinguish among sparse and valid data, as well as inferring new rules not formerly programmed. An interesting fact is that over the last five years, ML studies have focused on DL, high complexity algorithms that simulate human thinking. Therefore, this last sector of AI is still a matter of study and debate.

2. CONCEPTS TO BE CONSIDERED

ML techniques can be used to determine the quality of CAD design. The question is what technique is the best for each purpose? To provide a better understanding on the topic, the following paragraphs explain with more detail the differences among ML categories.

ML concept is divided into three categories: Supervised Learning (SL), Unsupervised Learning (UL) and reinforcement learning (RL).

SL is a technique that, knowing the characteristic of the input data, provides an algorithm capable of establishing relations and identifying similar data. I.e. this system relates input and output parameters.

Most problems considered in this category are classification or regression issues. Therefore, this type of ML is the most used now. For example, a SL algorithm can be trained to distinguish pictures of animals. If its trained to recognize elephants, when showing a picture the system will be able to tell if the animal contained is an elephant or not by obtaining characteristic elements from the data. Of course, the more data provided, the better the training. To train this algorithm we just have to provide a range of data and supervise the learning. In other words, the process would be like teaching a child to distinguish between photographs of dogs and cats.

In this specific area, the term “training” compounds the process to provide labelled data to

the algorithm, making adjustments on it depending on the predictions it is providing.

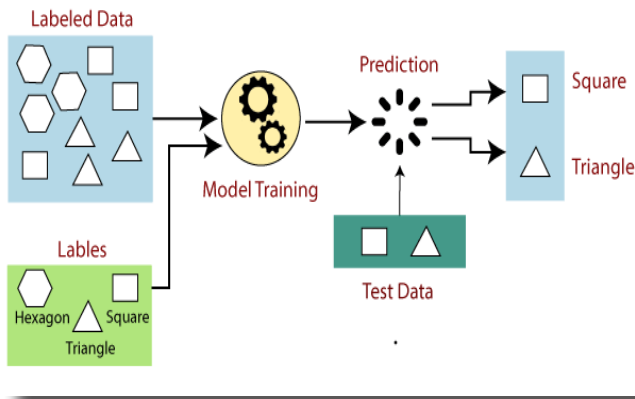

Figure 3: Diagram of Supervised Learning ML [7]

On the other hand, UL does not have information about the categories or characteristics of the data, but uses the algorithm to extract common features and group the input data in different groups or clusters. An example of this would be an algorithm capable of groping different animals in groups based on the common features it can find in them.

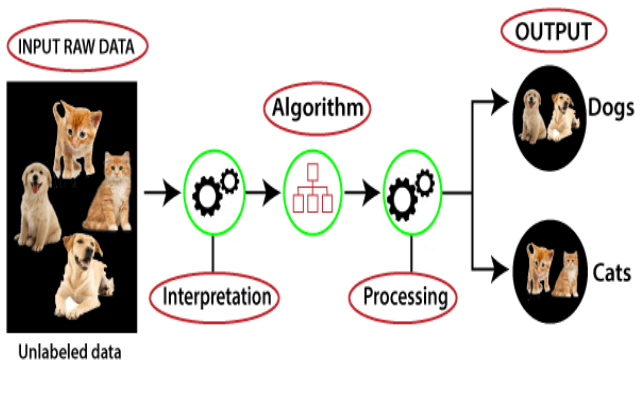

Figure 4: Diagram of Unsupervised Learning ML [7]

Finally, RL is characterised by the fact that the algorithm is updated through a continuous trial-error and reward-reward analysis, seeking the optimization of the latter concept in order to find the optimal combination for certain external conditions.

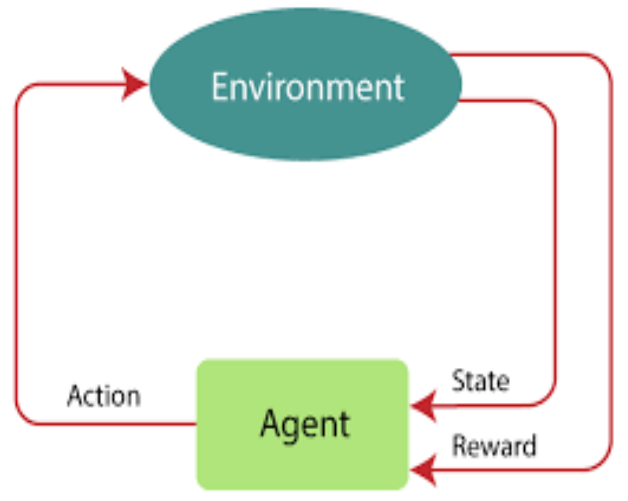

Figure 5: Diagram of Reinforcement Learning ML [7]

3. HOW TO APPLY ML TO SHIP DESIGN

The application of this technologies to ship design requires the identification of use cases in which added value is provided to the design process. Having this in mind, these can be used for multiple activities: standardization of objects or designs, automation of repeating tasks, identification of anomalies or outliers, design validation, etc.

The key element for all this is data. However, can we use any type of data? The answer is no. This data must be accessible, in great amounts and organized, otherwise the results will get with these technologies will not be valid.

Particularly, for the marine industry, we have found that generic data will not be of much use for the design of particular shipyards or technical offices want to do. On the other hand, shipyards and technical offices do not usually share specific data of a design, since it is what gives them value and allows them to differentiate themselves from each other. This leads us to conclude that to use AI technologies, the shipyard, office or naval designer, will need to create their own algorithms based on their own data.

Having all these factors in mind, in SENER we have developed a tool called FORAN Insights, which takes advantage of having FORAN's powerful relational and accessible database and is capable of analysing the data and extracting anomalies among it. The re-

sults of such powerful tool can be used in different stages of the life cycle of the ship, assuring fewer errors, timesaving and a wider standardization.

To develop this MVP, SENER has found key having experts both in data science and ship design, in order to find benefit to processes and select the best ML techniques for each problem.

We must keep in mind that ML is a complex science, often mistakenly applied to any process. The reality, however, is that many processes acclaimed under this term are merely classical frequency studies or simple optimization problems, where there is no technology other than classic arithmetic. Due to this fact, to obtain algorithms that provide valid results, it is key to have a professional data analyst or technical profiles that can distinguish between different technologies and the best way to apply them and designers with enough expertise to validate the results obtained by chosen algorithms.

4. CONCLUSION AND NEXT STEPS

Digital transformation requires adequate strategies to identify the added value obtained and compare it to the investments made. Moreover, in the current uncertainty we are living, particularly focusing on the shipbuilding business, a strategy that shows good results is to start with small projects that have sufficient viability to be evaluated without large investments (MVPs). It has been widely proved that this approach can provide good results, even exceeding expectations, without compromising too much on risks or investment. The key for success is to clearly define objectives and the profits we wish to obtain, as well as identifying the correct technologies to apply.

In the field of ship design, as we have shown before in this article, it is possible to use ML to identify anomalies on different parts of the lifecycle of the project. Thanks to FORAN Insights, an MVP developed by SENER, shipyards and technical offices shall benefit enormously by reducing design errors by detecting outlier parts on design phases. It also makes it possible to optimize the resources used, by ensuring the highest possible standardization of

parts, standardizing materials and manufacturing, which results in the reduction of design and construction costs.

As next steps, this MVP may be further developed, improving the parameters that allow users to identify and delimit the standard groups of parts. Also, this must be further integrated with the FORAN, allowing automatic and real-time detection to warn users of these possible anomalies.

Furthermore, the incorporation of visual tools for the presentation of results will facilitate the work of engineers for decision making. These tools are complemented by dashboards that have to be adapted and personalized depending on the users or the shipyard needs.

5. REFERENCES:

- [1]. MCKINSEY (2018). Unlocking success in digital transformations. McKinsey & Company.
- [2]. MCKINSEY (2019). Digital Transformation: Improving the odds of success. McKinsey & Company.
- [3]. LLOYD'S REGISTER et al. (2015). Global Marine Technology Trends 2030. Lloyd's Register, QinetiQ and University of Southampton.
- [4]. MUÑOZ J.A. and PÉREZ R. (2019). La integración de la Inteligencia Artificial en los procesos y metodologías de diseño naval. Ingeniería Naval, no. 978, pp. 74-84, March.
- [5]. MIERSWA.I, (2017), what is Artificial Intelligence, Machine Learning and Deep Learning? , <https://ingomierswa.com/2017/04/19/what-is-artificial-intelligence-machine-learning-and-deep-learning/>
- [6]. RAMIREZ, A.: PÉREZ, R. and MUÑOZ, J.A. (2020). Application of Smart Technologies to ship design. Smart Ship Technology, 14-15 October 2020, London, UK.
- [7]. KRANTHI K, 2020. Types of Machine Learning, <https://www.quora.com/q/mlforeveryone/TYPES-OF-MACHINE-LEARNING>

LNG AS ALTERNATE POWER SOURCE FOR MARITIME PROPELLING. GABADI S.L. AND THE MARK III TECHNOLOGY.

ANA BELLÓN // Operation Manager

JUAN GONZÁLEZ // Project Manager: "LNG Container Tanks 23 TEU"

GABADI S.L. // gabadi@gabadi.com

Liquated natural gas (LNG) is a gas converted into liquid status, by means of cooling system and preservation at cryogenic temperatures of -163°C . It is an alternate fuel, when compared to the others which are more polluting for the environment. Liquated natural gas has CO₂ and NO_x levels much lower than MDO (marine diesel oil) or than the HFO (heavy fuel oil) when being burnt, and its sulfur content is minimum.

As established within the international MARPOL convention, prescribed by the IMO, from the 1st of January 2020, it shall be compulsory to reduce 7 times the sulfur emissions in international waters (from 3.5% to 0.5%), in such a manner that the maritime transportation companies engage into more environmentally sustainable options, such as the aforementioned one.

Bearing this in mind, the company CMA CGM, big French containers transportation company which moves goods all around the world, has promoted the construction of a 9 environmentally sustainable container carries, which complete with the biggest ones in the world, with a capacity to transport 23,000 TEU (containers which are equivalent to 20 feet, and the particularity of being propelled by LNG. Even if it is possible for LNG to be the sole fuel, CMA CGM container carriers have dual propulsion. Their autonomy mainly depends on liquated natural gas, in such a manner that they will only need a small amount of fossil fuel, in order to start working without sulfur emissions and other components which are more polluting for the environment.

The CMA 23,000 TEU of 9 container carriers' series, being the first ones in the world to use LNG as a fuel, is being manufactured at the moment

at the shipyards China State Shipbuilding Corporation Limited (CSSC), provided that 4 out of the 9 are being built at the CSSC shipyard in Shanghai, Jiangnan Shipyard (Group) Co., Ltd. All the vessels of the series have an LNG storage tank for the propulsion of 18,600 cubic meters.



Image 1.- CMA CGM Jacques Saade containers carrier, first containers carrier in the world to be propelled by LNG.

The system which was selected for the containment of this gas at the fuel tanks at such a lower temperature is MARKIII system, designed by the French company GAZTRANSPORT & TECHNIGAZ (GTT), pioneer company in engineering system for LNG cryogenic containment. This tank, with corrugate shapes in its interior may bear the tem-

perature, due to the different insulating materials which are inside their walls which are 270-wide.

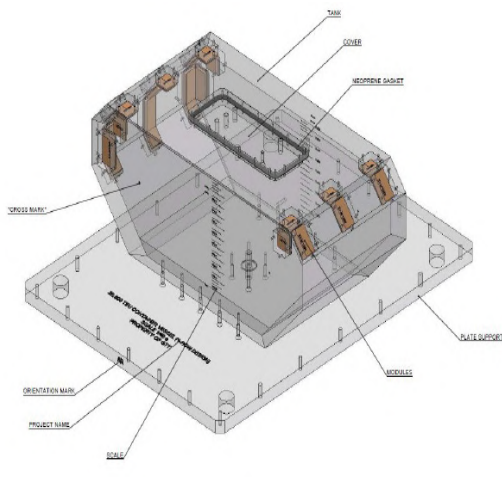
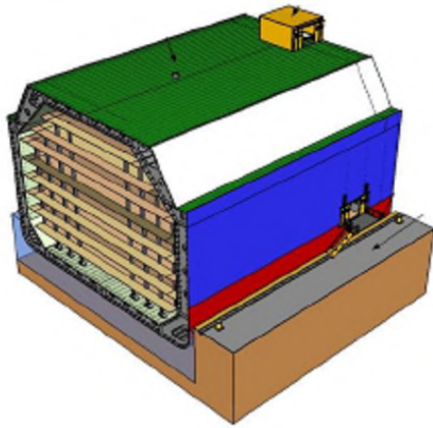

Image 2 a 3: Cargo tank diagram (Source: GTT ERECTION HANDBOOK), and design for fuel tank (Source: GTT B015 TANK ANA 1.1.9)

As the MARK III system is usually implemented at tanks inside vessels, it includes a secondary barrier and a primary barrier, in order to prevent big accidents, in case there was a leak at one of its barriers. The first of these barriers (secondary barrier) shall be a flexible fabric which is able to bear the contractions and expansions, resulting from the low temperature. The second one (primary barrier) is corrugated stainless steel, in order to contain the gas at its liquid status. Apart from these two

barriers, there are different layers of rigid foams and wood, which complete the insulating space.

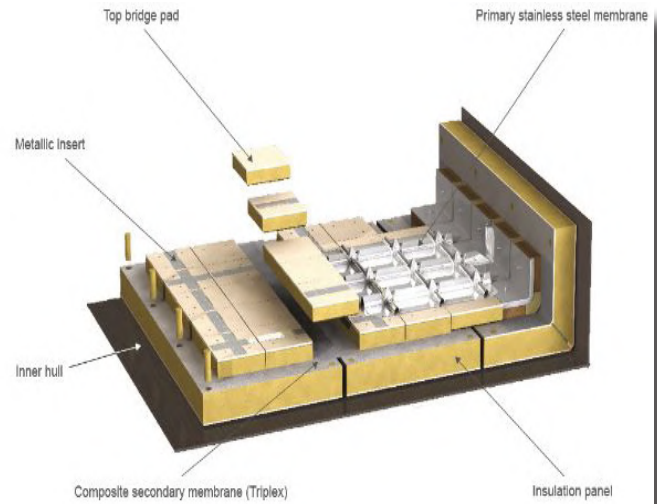
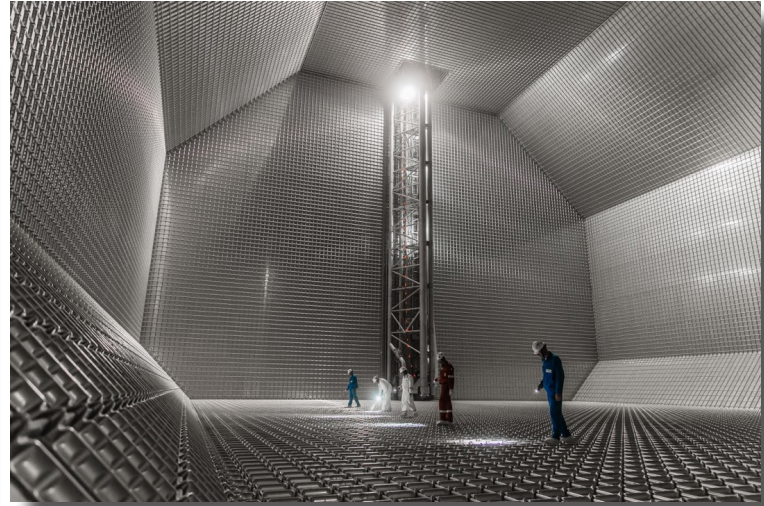

Image 4: Diagram of different components at Mark III insulation (Source: courtesy from GTT)

This system is usually implemented at big LNG carriers, carriers with central tanks throughout its length, in order to transport up to 250,000 cubic meters of liquefied natural gas. However, within this innovating project, the tank shall be used as fuel tank, with great autonomy to serve this big container carrier for its different travels around the world.

One of the main challenges of this gas tank is being able to appease the different phenomena which take place at the consumption tanks, such as the surfaces which are free, or the sloshing phenomenon.

The free surfaces phenomenon is known as the stability variation which occurs as a result of a liquid cargo movements inside the tanks, as the vessel crosses the waters. Within this tank, the cargo status shall be from completely full to completely empty (which does not occur, when it comes to traditional cargo carriers, which are aimed for cargo transportation from one port to another, without consuming the cargo, except for some residual quantity, as a result from boil-off or evaporation of liquefied natural gas). If the traditional design was used, the vessel's stability would be compromised, because the tanks' height usually is 70% of the tank's width.



Images 5 and 6: Tank with modified design for reduction of free surfaces and conventional cargo tank (Sources: Image 5 (upper) <https://gcaptain.com/chevrons-new-lng-vessels-highlighted-in-surprisingly-good-corporate-video/>, Image 6 (lower): Roland Mouron)

In order to prevent this free surface phenomenon, GTT has thought of increasing the low hoppers proportionally, by reducing the width as the gas is consumed, and, consequently, reducing the liquid mass quantity which is moved from one side to the other.

Regarding the sloshing, it consists of sharp liquid mass movements which occur inside the tank, by hitting the walls which contain that gas at cryogenic status. This phenomenon could endanger the integrity of the tank's bulkheads itself.

For that reason, the implementation of the designs with more rigidity, including the high density foams and reinforcing the primary barrier with aluminum matrix at its interior, which shall allow the contraction and expansion due to the temperature, but it shall prevent sharp damages, due to waves caused inside the tank.

Once the technical challenge implied with the patented GTT design is overcome, the production challenge of the tank insulation is assumed by Jiangnan with the cooperation of Gabadi Marine Engineering (Shanghai) Co. Ltd. and the GTT assistance. Gabadi

Marine Engineering (Shanghai) Co. Ltd. is a Chinese company in which the Spanish company Gabadi S.L. has shares that received the award in 2018 for the installation of the Cargo Containment System (CCS) for the LNG tanks for the CMA CGM container carriers, provided that Gabadi S.L. is one of the few companies in the world, specialized in performing works for gas tanks, having build prototypes and performed big repairs around the world.

Gabadi S.L. is licensed outfitter for new constructions of LNG tanks and approved repair works subcontractor for LNG tanks repairs, with both qualifications from GTT. In the world, there are only 5 licensed outfitters and 4 approved subcontractors. This given an idea about the exclusivity and high qualification which is required for the works performed by Gabadi S.L. under the patent from GTT.

The turnkey Project which is executed at Jiangnan shipyard in China has implied many challenges for the company. At the beginning, the project was a great technical challenge, because it was the first work for Gabadi S.L. as licensed outfitter, supplying and installing a full tank to a vessel in construction

process, with the corresponding coordination with the shipyard. This challenge was overcome by far, with a significant investment made in machinery, and mainly in human resources with the corresponding professional training and qualification, which were necessary to execute the different stages for the new building of the gas tank.

The second challenge has been the human resources. Gabadi S.L. has kept more than 70 professionals at 10,200 km from its headquarters in Spain since the beginning, in 2021, and provided the impact since early 2020 of Covid-19 pandemic, which started in China by early 2020. This pandemic involved several difficulties for the European workers mobility. Once again, as of today, the challenge has been overcome, by means of an ambitious training plan for local employees, and an excellent management of the human resources, which has allowed Gabadi to transform within 6 months a workforce which was composed in 90% of European workers, into one made of 25% of European workers and 75% of local employees.

At present, Gabadi S.L. has delivered already 3 out of the 4 tanks of the 23,000 TEU CMA project. Additionally, its great background as licensed outfitter has translated into a new contract for 3 new tanks within the 15,000 TEU project which CMA CGM has awarded to Jiangnan shipyard, which promotes a new international cooperation with its vast experience, including both nationalities.

Without a doubt, a fantastic Chinese-Spanish cooperation, in terms of the cargo containment system installation for the LNG tanks to be used as a fuel for container carriers. At present, Gabadi S.L. intent is to continue putting faith in this kind of projects, despite their mobility and logistics difficulties, while showing proof of great capacity to grow in a fully international market, and promoting its cargo tanks repairs and new building projects, both for gas to be used as vessel fuel, or onshore tanks, which implement the membrane technology systems for the containment of liquated tanks at cryogenic temperatures.



Image 7: GABADI S.L team, celebrating the delivery of the first liquated natural gas tank with the MARKIII system, for the 23,000 TEU CMA CGM Project, executed at Jiangnan Shipyard, at the CSSC shipyards.

THE FIREFIGHTING BOAT AISTER MZ12

JUAN A. OLIVEIRA // Author of: "vadebarcos.net"

Naval and Oceanic Architect & MBA // vadebarcos@gmail.com



One of the latest deliveries from the Vigo shipyard Aister is the rescue and fire-fighting vessel AISTER MZ12 which will operate at Sir Seewoosagur Ramgoolam International Airport in Mauritius. The boat, 11 meters long and built completely in aluminum, has two monitors for fire fighting with a capacity to launch 240 cubic meters per hour, about 4,000 litres of water per minute.

Located in Moaña, on the northern shore of the Vigo estuary, Aister has been building professional aluminium vessels such as patrol boats, passenger catamarans, workboats or rescue boats for various State Security Forces such as the Civil Guard, the Spanish Navy, the Military Emergency Unit (UME) or Navantia for more than 30 years.

Aluminium offers Aister the possibility of joining aesthetics, comfort, navigability and durability in all its products, through the use of a high quality alloy and a perfect execution in the welding that makes the material does not lose any of its mechanical properties. In this way the shipyard can offer safe, resistant and durable boats, with low maintenance costs and their own characteristics.

More than 100 professionals make up Aister, distributed between its own technical office, formed by industrial engineers, naval engineers and architects, and its workshop staff, boilermakers and welders, located in a 25,000 square metre facility on the waterfront and with direct access to the sea, which allows them to deliver their boats ready

to sail, saving transport costs for their customers.

This new boat is part of the new range of smaller boats with different customisation possibilities launched by the shipyard, which allow the owner to include different elements such as anti-pollution or fire barriers, adapting to the needs of the client in each project.

In this case, the boat followed the parameters set by AML (Airports of Mauritius Co Ltd), which manages the Sir Seewoosagur Ramgoolam International Airport in the Mauritius Islands, located in the Indian Ocean, about 500 kilometres east of the island of Madagascar and 2,000 kilometres from the African continent, although the boat will be operated by the country's coastguard in order to ensure safety at the airport in compliance with International Civil Aviation Organisation (ICAO) directives, which requires a rescue, salvage and fire-fighting boat at airports close to the sea.

The AISTER MZ12 has an overall length of 11 me-

tres, with an aluminium hull surrounded by a polyethylene fender. Its deck is continuous, interrupted only by the central cabin, which allows 360-degree visibility thanks to its windows on the sides and roof; the cabin is surrounded by two exterior side corridors that allow passage from bow to stern facing the monitor stations. The monitors are powered by a diesel motor pump located aft under the cockpit, with a capacity of 240 cubic metres per hour, about 4,000 litres of water per minute. Two 250 horsepower outboard engines allow the boat to glide at a maximum speed of 32 knots in a very stable and manoeuvrable manner.

The delivery of the vessel included a training and technical support programme in the field, with an Aister team travelling to Mauritius to show local coastguards how the vessel works. The training covered the different areas and functions of the vessel: pilot's station, crew members in charge of rescue manoeuvres, those responsible for surveillance as well as maintenance.



EMERGENCE OF THE HAZARDOUS MATERIALS AGREEMENTS

VÍCTOR SOLANO // Lloyd's Register

New Construction Client Manager // Senior Surveyor, Marine & Offshore

In this moment, where the analysis of environmental impacts is gaining significant value, it is not only within the industrial engine, also as a growing social demand, the shipbuilding industry and the maritime sector, understood that they should follow this wake, seeking a rational exploitation of their ships that would culminate in safe recycling; in short, to promote a responsible life cycle.

From the mid-1980s, the centre of the ship scrapping industry shifted towards Asia, in particular to India, Bangladesh and Pakistan. This industry was, and still is, virtually unregulated and has one of the worst safety records of any industry. It also causes massive environmental pollution.



It is important to highlight that industries are developing, with knowledge, innovation and social demands. In this sense, certain aspects, such as safe working conditions, minimization of possible adverse impacts and policies oriented towards corporate

sustainability have gained value in recent years, promoting policies with a greater social burden.

In order to address these issues, industry working groups developed the Industry Code of Practice on Ship Recycling. This guidance subsequently fed into discussions at the International Maritime Organization (IMO), which resulted in the IMO Guidelines on Ship Recycling, adopted by member states in December 2003.

Initially, these guidelines were voluntary and introduced, for the first time, the concept of inventory, formerly known as "Green Passport".

With these guidelines, a path was started aimed at the control of hazardous materials installed on board the vessels and, their subsequent recycling treatment. As a consequence of the promulgation of several guidelines, an international agreement finally emerged published by the International Maritime Organization, as well as, a regulation for ships ordered within the European Union; both instructions consider standardization in new building as well as in existing vessels.

Currently, and due to the international emergency situation we are experiencing, the European authorities, aware of the slowdown in all sectors, have proceeded to give a 6-month deadline for the application of these regulations with regard to existing vessels and, as long as, it is demonstrated by the owning company that the process for obtaining the inventory of hazardous materials has been initiated and is ongoing.

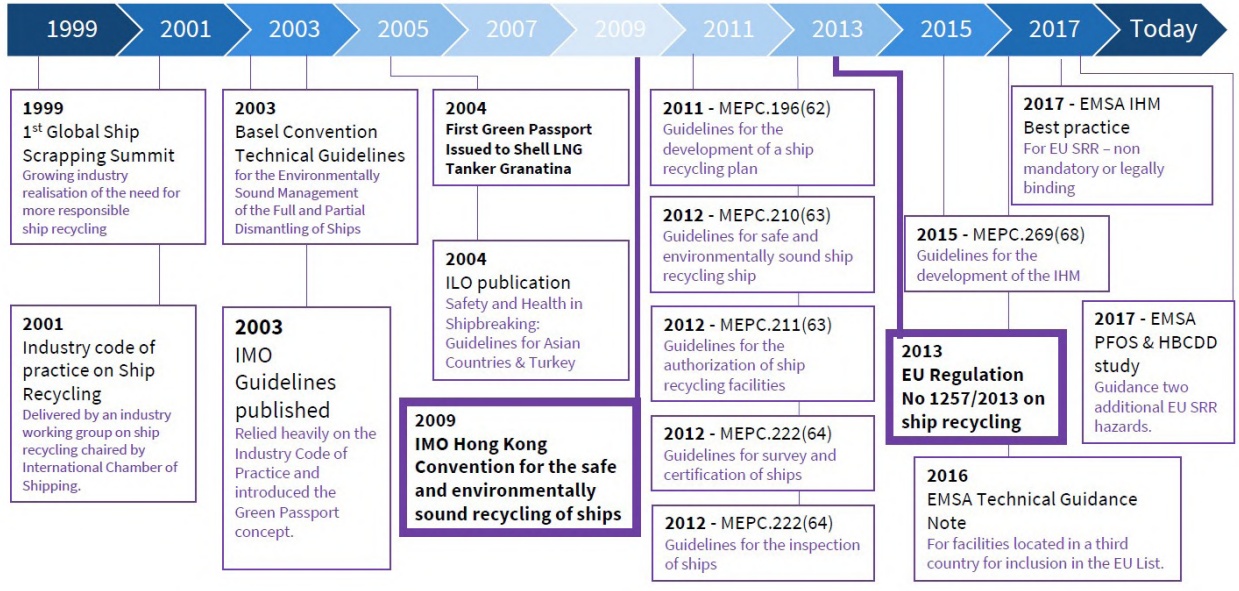

Evolution of regulations applicable to vessel recycling



Courtesy Barreras

Topflight Ship Design Experience

SENER Design and Engineering

SENER ensures the highest quality from Concept Design to Production Engineering since 1956, bringing affordability and innovation.



www.marine.sener

THE HONG KONG CONVENTION

At the 53rd session of its Marine Environmental Protection Committee (MEPC 53), the IMO decided that the situation required proper regulation, therefore, the Draft IMO Convention for the Safe and Environmentally Sound Recycling of Ships was developed. The timetable for this Convention was extremely ambitious from its conception in July 2005, the intention was to have the Convention adopted during the biennium 2008/2009.

Although the effort to have a firm and consolidated regulation was a responsibility, there was already an important previous work, thanks to the studies that led to the Basel Agreement and the existing directives in the original Lloyd's Register inventory, known as the "Green Passport", and that were a support in the definition of the current "Inventory of Hazardous Materials" (IHM).

The top five vessel recycling countries in the world, among which represent more than 98% of all ship recycling by gross tonnage, are Bangladesh, China, India, Pakistan and Turkey (of these, two are now part of the Hong Kong Agreement – India and Turkey).

With India's adherence, in November 2019, With India's adherence, in November 2019, the required number of states has been reached, but more tonnage and volume of recycling is needed before the convention can enter into force.

The current Contracting States are; Belgium, Congo, Denmark, Estonia, France, Germany, Ghana, India, Japan, Malta, Marshall Islands, Netherlands, Norway, Panama, Serbia and Turkey.

THE UE RECYCLING REGULATION

The EU Regulation on Ship Recycling entered into force on 30 December 2013. It will apply to ships of at least 500gt flying the flag of an EU member state, and to ships visiting the EU flying the flag of a non-EU member state.

The Regulation is, mostly, aligned with the Hong Kong Agreement, differing mainly in two aspects, such as: the inclusion of two substances in Part I of the convention; one in Table A thereof (PFOS substance) and one in Table B (HBCDD substance); and,

in the possibility of including additional criteria on the part of the vessel's flag.

THE HAZARDOUS SUBSTANCES REPORT

On both regulations, the Hong Kong Agreement and the European Regulation, it is clearly marked who will be responsible for the completion and maintenance of the report on hazardous substances during the construction process, as well as throughout the entire operational life of the ship, until its recycling.

In this sense, it is understood that the vessel's builder shipyard will be in charge of evidencing the traceability of all the materials used in the manufacture, therefore, providing the mentioned report with the delivery of the vessel. From then on and throughout the remaining life cycle, it is the responsibility of the shipowner to ensure its updating and the traceability of new materials resulting from repairs and future needs of the ship.

In this line, and for those vessels that were already in service at the time of these regulations, the owner of the named should be the one who is responsible for preparing and updating afore mentioned document. The development of the hazardous materials report (IHM) shall be carried out in an objective manner and by competent personnel, thereby ensuring the purpose of the report.

As a summary, the following are the aspects that the Hazardous Materials Inventory report must contain, differentiating them by new construction and vessel in service:

New Building Project:

- Information about the type of vessel and its shipping company
- List of equipment, materials, products and paints used during the constructive process and which form part of the vessel.
- Materials declaration on the part of manufacturers of all equipment, materials, products and paints.
- Plans of the vessel identifying the areas where hazardous materials are located.
- Inventory of hazardous materials

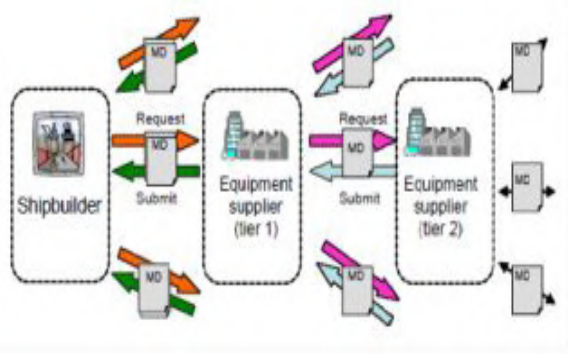

In-service vessel

- Information on the type of vessel and its shipping company.
- Sampling of equipment and materials installed on board.
- On-board sampling collection plan.
- Tests, in accredited laboratories for this purpose, samples taken on board.
- Risk analysis in each case
- Plans of the vessel of the ship identifying the areas where the hazardous materials are located, obtained from previous sampling
- Inventory of hazardous materials

THE HAZARDOUS MATERIALS INVENTORY

It is important to note that this document shall always be available, on board the vessel, and will be considered a “living” document, in other words, any modification that happened on the structure, surface treatment and / or installed equipment, after repair or refitting update, must be reflected in it, as long as it is shown that such material / product contains, or is suspected of containing, some

dangerous substances.

The information contained in this document is structured in three clearly differentiated parts:

Part I; whose purpose is to include the materials that make up the structure and equipment of the vessel, such as:

- i. Paints
- ii. Equipment and machinery
- iii. Structure and hull

Part II; where the garbage generated as a result of the vessel’s operation is taken into account:

Part III; definition of hazardous materials stored on board the vessel:

- i. Hazardous materials stored
- ii. Liquids containing dangerous substances in machinery and equipment
- iii. Gases contained in machinery and equipment.
- iv. On-board equipment consumables

It should be noted that during the operation of the vessel, the HHI will consist only of Part I as described in the Hong Kong Agreement and/or the European Regulation, since parts II and III will be included in the list of hazardous materials when the owner requests the final scrapping of his boat.

The mission of this inventory is to maintain detailed and accurate information in order to typify the nature of each future waste and to define its correct management, taking into account the legal requirements of each country.

Once again and, therewith, the aim is to seek a responsible life cycle, taking one more step on the path to a sustainable industrial model.

INTERVIEW WITH: América López & Nohaila Chhaim

TALLERES LÓPEZ VILAR S.L.



América López (CEO) // america@lopezvilar.es

Nohaila Chhaim (CMO) // comercial@lopezvilar.es



Talleres López Vilar, S.L. was created in 1974, showing the capability to adapt and read when it comes to identifying needs and market demands ever since. You are currently specialised in the building and repair of aluminium boats, motorisation, engine repairs, aluminium and steel structures, supply of FAD etc.:

- What would you say, with all the experience you treasure, is the future of the shipbuilding sector in Galicia and the factors to take into account?

Bearing in mind that Galicia was in full international commercial expansion, covering all of Europe, among other territories, the situation has caused a generalised slowdown in all sectors; although we will surely compete and recover the level of expansion that we had, or even better.

- **Are your company's competitors at the regional, national or international level? What is it that makes you different from your competitors?**

We could say that almost all of our competition is at international level, there are no direct competitors at regional or national level given our specialisation. Which is based on the specific market, such as the tuna market. We have evolved as developments in tuna fishing have taken place, adapting to the standards required at any time.

Where we seek differentiation is in the supply of products and services with the best quality, from the selection of the raw material we look for the

highest quality. We offer individualised, valued services, such as after-sales services. In our FAD business line, for instance, we are always at the forefront, the work of technological surveillance allows us to anticipate international requirements, such as the ISSF international councils, to name just a few. We have just developed a biodegradable prototype for tuna fishing, which has been approved by these institutions.

- **Would you say that this way of competing has changed at present?, In what sense?. Both in the national and international markets, do you consider that there has been any significant change in the way of doing business, of obtaining contracts?**

Yes, it has changed, due to the economic difficulties of recent years, there is more and more intrusion coming from other sectors. We cannot lower our guard and we have to be the best in the areas in which we compete.

Another important change is that the sector is becoming more professional, more demanding. The incorporation of young and highly qualified people into the staff, of new and updated methods, more competitive, undoubtedly raises the level of demand when it comes to obtaining contracts. Both nationally and internationally.

- **What customers do we need to attract?**

From our point of view, clients from the European

market, especially from northern countries. Powerful shipowners who know and are interested in Galician shipbuilding

- **What is the biggest challenge you have faced with the company?**

When the generational change from the previous to the new management took place, although it was done gradually. The new management brought a lot of enthusiasm and a more general vision with the idea of opening up new lines of business.

- **Do you regret any of the business decisions you have made, would you have modified any of these decisions?**

No, in such case, we err in excess of prudence at the time of making certain decisions.

- **About the lack of skilled workforce, Do you have difficulties finding workers with the skills you require?, Would you improve this aspect in any way?, What can be done to make the industry more attractive to young people?**

Sometimes we do have problems finding people with the specific training we need. We believe that the sector should be in closer contact with the training centres, create a closer communication so that companies can inform about what they need in terms of certifications. On our part, we maintain contact with professional training centers, College of Naval Engineers, FEUGA ...

It would also be very helpful to facilitate access to internships for recent graduates, those finishing vocational training, or any other type of training. I might use myself as an example: at the beginning the sector does not attract your attention from the outside, it scared me a little, but when you are inside it, little by little you start to like it and become more and more interested in it. Practical training would help many more people to get first-hand knowledge of an attractive and interesting sector.

- **Do you find difficulties for the development of your activity: infrastructures, transport, logistics, environmental regulations?**

No, we have no difficulties, neither with transport nor with logistics. We have many years of experience and we have a well established network in these aspects. In addition, we have the advantage of our geographical position, it is strategic, and we have

the port of Vigo nearby, which is very relevant at an international level.

In terms of regulations: they are not a handicap, our buildings are made of 100% recyclable aluminium. We are adapted and do not suffer from this type of regulations.

- **Do you really believe that the application of new technologies, the much talked about Industry 4.0, will be a reality applicable to your activity in the coming years?**

We don't think directly for our company, but for our suppliers, who are already implementing it. Therefore, it indirectly benefits us, for example, in the development and research of new materials, in the traceability of products, production ...

- **Could you tell us the advantages - disadvantages and strengths - weaknesses that you consider of the region?**

One of Galicia's strengths is that it has always been considered a reference in shipbuilding, something that benefits all ancillary companies. In our case, the proximity to the Port of Vigo is also important, which is a world reference in fishing, and that is a very great advantage.

One disadvantage has been the lack of support for a long time for the industrial development of the region, we are at a disadvantage with the rest of the national territory, with regions that do have this aspect more consolidated.

- **Does the Shipbuilding Sector work together?, How does it look from an ancillary company?**

It does not work together, many times for companies like ours it is very difficult to be included in large projects, access is not easy and participation is not facilitated as much as it should be.

- **How does Talleres López Vilar envisage the future?**

We consider it by overcoming this current stage, so uncertain, and going back these years with new projects and lines of business, opening the market. We do consider that Talleres López Vilar has a lot of potential to exploit, working on the professionalization of our technicians and on the improvement of machinery; to be able to cover more services and projects.

THANKS FOR SUPPORT:

Puerto de Vigo



Detegasa (Grupo Argos)



Pipeworks S.L.



Sener Ingeniería



Exponav



Gabadi S.L.



Lloyd's Register



"vadebarcos.net"



Talleres López Vilar S.L.



VIGO: Plaza de Compostela nº19, 3ªizquierda. 36201 Vigo, Pontevedra

FERROL: Edificio CIS Tecnoloxía e Deseño
A Cabana s/n, Desp.1.1-15590 Ferrol, A Coruña

Teléfono: 981 57 83 06

Fax: 986 90 52 83

aclunaga@aclunaga.es